

EMS*plus*TM

QUICK START GUIDE



Required Tools

- Standard hand tools
- Standard electrical tools
- Volt meter
- Amp meter
- Tachometer
- Drill
- 1-1/4 drill bit for stainless steel
- Level
- Ladder
- Fire System cocking tool

Required Equipment

- Ventilation Hood
- Fire System
- EMS*plus* Control Panel
- Exhaust Fan(s)
- Supply Fan(s)
- Dampers in Supply duct if 1 supply fan is serving multiple exhaust fans

Required Materials

- Electrical Conduit & Wire
- Fire System Supplies
- Exhaust Ductwork
- Supply Ductwork
- Temperature Sensor or Sensors
- Thermistor 2-wire plenum rated Cable
- CAT-5 cable if Touch Screen is mounted remotely

INSTALLATION

1 EMSplus Panel

The EMSplus Panel comes in different size boxes. These boxes can be installed inside a utility cabinet or wall-mounted. If the panel is installed in a utility cabinet, the VFD are mounted outside the panel. If the panel is wall mounted, the VFD are installed inside the panel.

WARNING

If the box contains a VFD, it is vented and the entire EMSplus box should NOT be mounted recessed into a wall. Without sufficient airflow, the VFDs could overheat and sustain damage.

2 Temperature Sensor

Install the temperature sensor(s) (Thermistor) into the exhaust risers. See detail below.

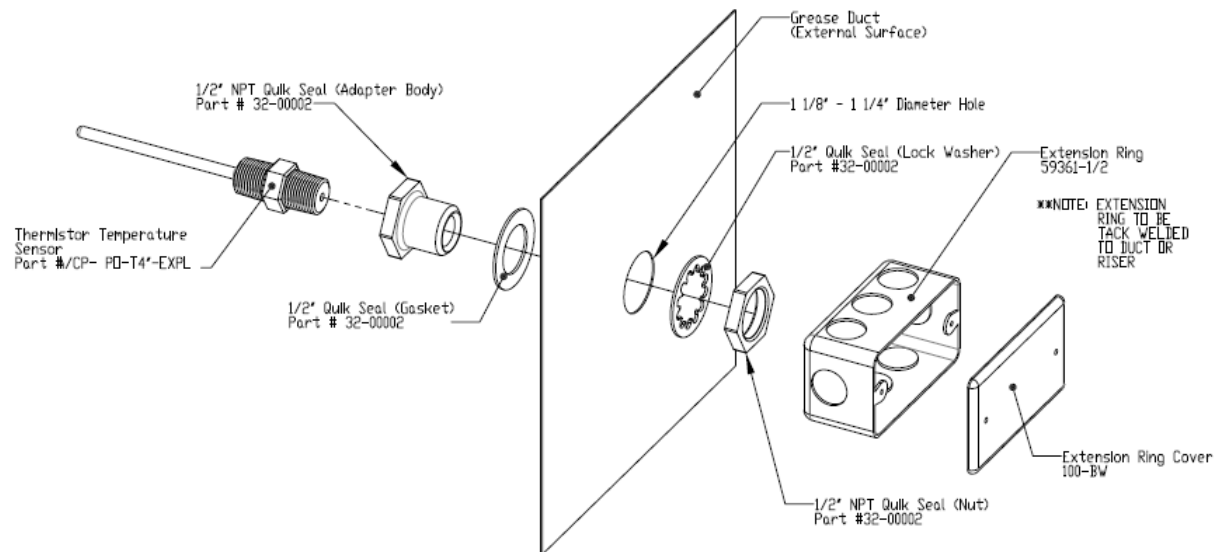

3

Single / Three Phase Power Input



DANGER! Hazard of electrical shock!
Circuit potentials up to 600 VAC are possible. Capacitors retain charge after power is removed. Disconnect power and wait at least three minutes before servicing the drive.



STOP!

- Verify mains voltage before connecting to drive.
- Do not connect mains power to the output terminals (U,V,W)! Severe damage to the drive will result.
- Do not cycle mains power more than once every two minutes. Damage to the drive will result.

Wire the input power to the VFD drive using the L1, L2, and L3 terminals on the right hand side of the VFD.

If the drive is not mounted inside the EMSplus enclosure, wire the ground from the breaker panel to the PE terminal on the drive.

WARNING

Wiring the input power to the output will severely damage the VFD. Check that the correct power source is supplied to the VFD and that the L1, L2, and L3 terminals are used.

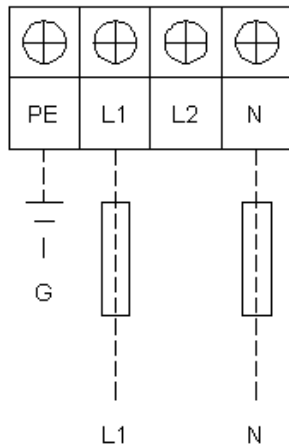

**120V 1PH
POWER INPUT**

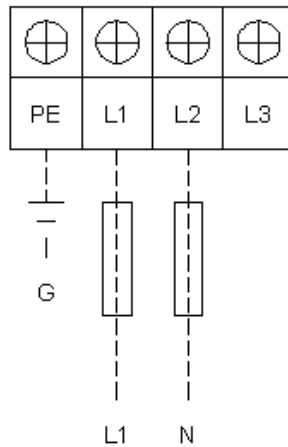

**208/230V 1PH
POWER INPUT**

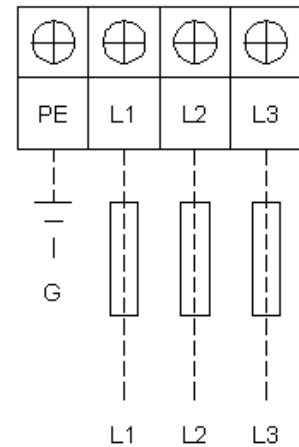

**208/230/460V 3PH
POWER INPUT**

4 Three Phase Power Output



DANGER! Hazard of electrical shock!

Circuit potentials up to 600 VAC are possible. Capacitors retain charge after power is removed. Disconnect power and wait at least three minutes before servicing the drive.



STOP!

- Verify mains voltage before connecting to drive.
- Do not connect mains power to the output terminals (U,V,W)! Severe damage to the drive will result.
- Do not cycle mains power more than once every two minutes. Damage to the drive will result.

Wire the output power to the exhaust and supply fans from the VFD terminals U, V, and W on the left hand side of the VFD.

- Refer to VFD installation instructions below
- Check for fan power source voltage and phase
- Check for proper belt tension
- Record any changes to the fan pulleys or belts

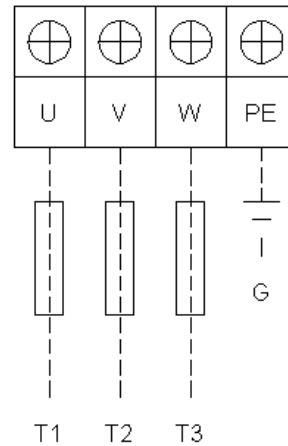

POWER OUTPUT

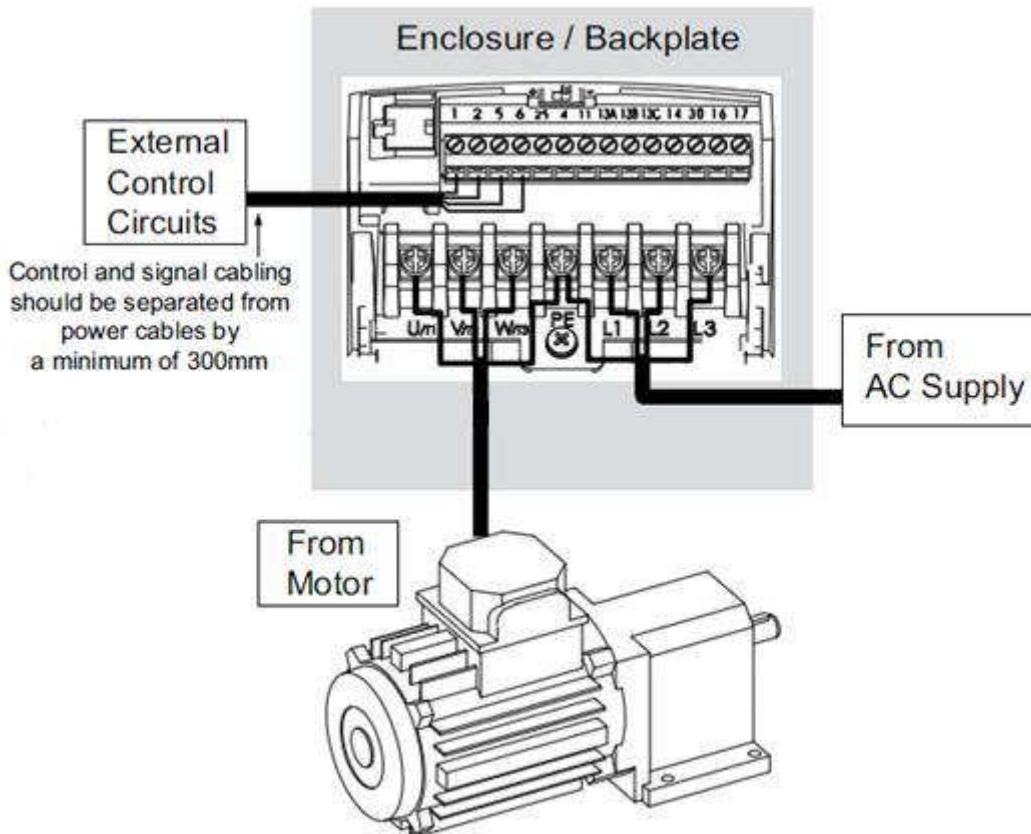

5

VFD Installation Instructions

Input AC Power

1. Circuit breakers feeding the VFDs are recommended to be thermal-magnetic and fast acting. They should be sized as 1.5 times the input amperage of the drive. Refer to ACTECH SMV VFD Cross Reference table in "Installation, Operation, and Maintenance Manual."
2. Each VFD should be fed by its own breaker. If multiple VFDs are to be combined on the same breaker, each drive should have its own protection measure (fuses or miniature circuit breaker) downstream from the breaker.
3. Input AC line wires should be run in conduit from the breaker panel to the drives. AC input power to multiple VFDs can be run in a single conduit if needed.
4. The VFD should be grounded on the terminal marked PE.
5. DO NOT FLIP the VFD up side down.

STOP!: DO NOT connect incoming AC power to output terminals T1, T2, T3. Severe damage to the drive will result.

Output Power

1. Motor wires from each VFD to its respective motor MUST be run in a separate steel conduit away from control wiring and incoming AC power wiring to avoid noise and crosstalk between drives.
2. Load reactors: If the distance between the VFD and the motor is great, a load reactor should be used between the VFD and the motor. The output reactor should be sized accordingly.
208/230V – Load reactor should be used when distance exceeds 300 feet.
460/480V and 575V– Load reactor should be ordered when distance exceeds 150 feet.
3. If the distance between the VFD and the motor is between 500 and 1000 FT, a dV/dT filter should be used.
4. No contactor should be installed between the drive and the motor. Operating such a device while the drive is running can potentially cause damage to the power components of the drive.
5. When a disconnect switch is installed between the drive and motor, it should only be operated when the drive is in a STOP state.

Programming

1. The Drive should be programmed for the proper motor voltage. P107 is set to 0 (Low) if motor voltage is 120 VAC, 208 VAC or 400 VAC. P107 is set to 1 (High) if motor voltage is 230 VAC, 480 VAC or 575 VAC.
2. The Drive should be programmed for the proper motor overload value. P108 is calculated as Motor FLA x 100 / Drive Output Rating (available in ACTECH SMV VFD Cross Reference table in "Installation, Operation, and Maintenance Manual").

Refer to "Installation, Operation, and Maintenance Manual" for instructions on how to access the Program mode of the VFD.

3. P500 parameter provides a history of the last 8 faults on the drive. It can be accessed without getting into PROGRAM mode.

WARNING

All field wiring must be completed before starting the unit for proper operation.

6 120V Control Power & Ground

The EMSplus panel requires a separate 120 volt power source for the lights, controls and micro switch. The 120 volt power source should be wired to terminals H1, N1 from a 15 amp breaker.

If there are multiple hood light circuits on the system, additional 120V input power sources from 15 amp breakers should be wired to terminals H2-N2, H3-N3 etc.

The ground should also be run and wired to the GND terminal. It should be sized for the total load of the panel: Controls (5 amp)+ Lights + all drives load. Refer to table attached.

GROUND Wires THHN, THWN, THWN-2	
Total load	Wire Size
15	14 AWG
20	12 AWG
60	10 AWG
100	8 AWG

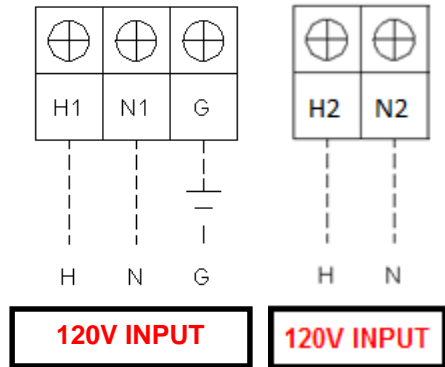

7 Temperature Sensor Wiring

The temperature sensors will need to be field wired to terminals Si and Sj where i and j have different values depending on the location of the sensor. Refer to the installation drawings for exact terminal names. Thermistor wire should be used and it should be run into the panel using conduit.

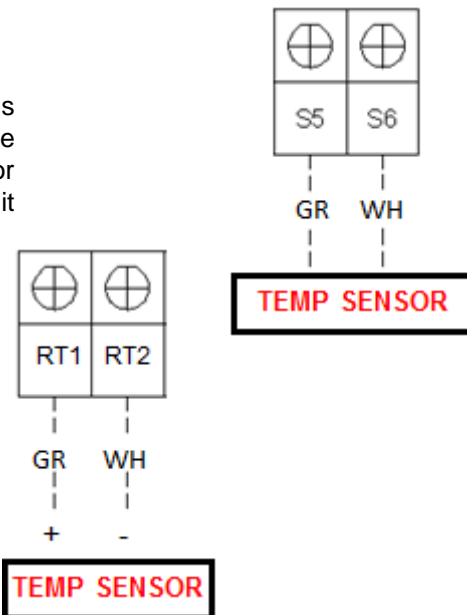

8 Room Temperature Sensor

The room temperature sensor should be mounted in the kitchen away from the hood and appliances. It should be wired to terminals RT1, RT2.

9 Hood Light Wiring

The hood lights will need to be field wired to terminals B and W. The wires should be run into the panel using conduit.

If there are multiple hood light circuits on the system, additional hood lights should be wired to terminals B2-W2, B3-W3 etc.

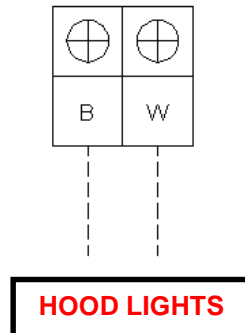

WARNING

All field wiring must be completed before starting the unit for proper operation.

10 Micro Switch Wiring

The hood fire system micro switch should be wired to terminals C1, AR1, and TR1. The wires should be wired into the panel using conduit.

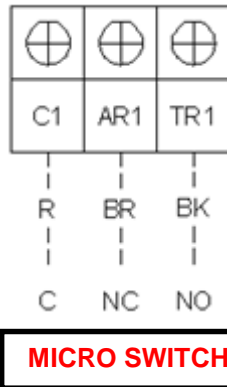

11 Control Wiring to Tempered Make-up Air Unit

If the EMSplus panel controls a Dedicated Tempered Make-up Air Unit (MUA), the 120V control power to the MUA has to be fed from the EMSplus panel. Two wires should be run from terminals RH1 and N1 inside the EMSplus to terminal 7 on the disconnect and terminal block N inside the MUA.

If the EMSplus controls 2 MUA units, the second MUA controls power should be fed from terminals RH2 and N1 of the EMSplus panel.

In addition to the control power, the MUA interlock signal has to be run back to the EMSplus panel to indicate when the motorized damper has reached the end limit switch. This will then allow the blower inside the MUA unit to run. From MUA terminal D7 and D3, run **low voltage** wires to terminals D7 and D31 for MUA #1 and D7 and D32 for MUA #2. Make sure this is run in a separate conduit from the 120V and motor power wiring.

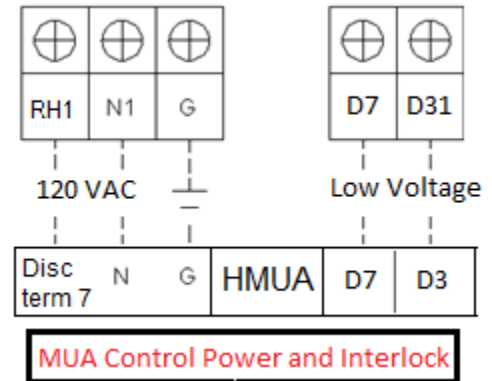

12 Cooling Interlock for MUA or RTU

If the EMSplus panel controls a Dedicated Tempered Make-up Air Unit with Cooling, the 2nd stage cooling should be interlocked to only operate when the supply fan is running at or near high speed. Two wires should be run from terminals 16-17 on the Supply fan VFD to the MUA and wire in series with the cooling thermostat second stage contact.

If the system does not have a dedicated supply fan and the make-up Air is provided by a Roof Top Unit, a dry contact is available inside the electrical panel between terminals Y2C and Y2T to interlock the second stage cooling of the RTU.

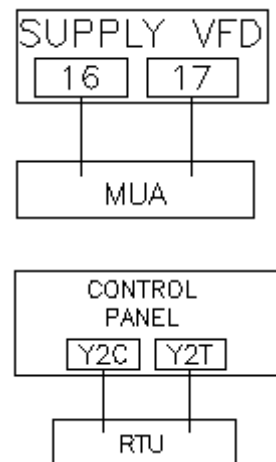

13

Supply Duct Dampers (Motorized)

If the EMSplus system include supply duct dampers, they must be installed in the main supply duct above each exhaust fan.

120VAC motorized dampers should be wired to terminals SD_i and N₁ where i represent the exhaust number it is associated to.

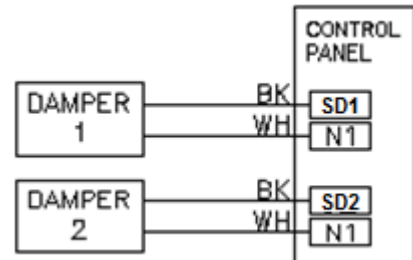

14

BACNET Communication

If the EMSplus system include BACNET Network, plug in the CAT-5 Cable directly in the Ethernet port (RJ-45) of the main controller

INSTALLATION CHECKLIST

- Temperature Sensor(s) mounted into the hood risers
- Exhaust VFD 3-phase or 1-Phase input to L terminals on VFD
- Exhaust VFD three phase output from U, V, and W on VFD to exhaust fan(s)
- Supply 3-phase or 1-Phase input to L terminals on VFD
- Supply VFD three phase output from U, V, and W on VFD to Supply fan(s)
- 120V Circuit to H1, N1 (H2, N2...)
- Ground wire from breaker panel to EMSplus panel
- EMSplus Sensors wired to Si and Sj
- Hood Lights wired to B and W (B2, W2...)
- ANSUL Microswitch wired to C1, AR1, and TR1
- Room Temperature Sensor wired to RT1, RT2
- 120V power to Heated Make-up Air on RH1 and N1
- Cooling Interlock to Make-up Air on 16-17 of VFD or to RTU on Y2C-Y2T inside panel
- Supply Duct Dampers installed and wired to terminals SD1, N1, SD2, N1 etc.

START UP

1 Power

- Make sure the control circuit breaker inside the panel is OFF.
- Make sure Fire System is armed.
- Turn the breakers feeding the VFDs and the Controls ON. All VFD(s) should display STOP. If you see an error on the drives, refer to the troubleshooting manual.
- Verify proper voltage at VFD terminals L1, L2, and L3
- Verify 120 volts between terminals H1 and N1.
- Turn ON the control circuit breaker inside panel
 - The Controller lights should illuminate
 - All VFD display should read STOP (unless temperature in the duct is above the low set-point in which case the VFD will ramp up to 48 Hz or more).



2 Hood Lights

- Press the light icon. If multiple light circuits, press each light circuit individually.
- Verify all lights are in working order



3 Fan Test

- Turn the fans ON by pressing the Fans Icon. If they are multiple fans, press the All Fans icon. Also press the Prep OFF button if the system goes in Preparation Time.
 - The fans will gradually accelerate
 - All VFD(s) will accelerate to 48 Hz
 - If Supply fan doesn't run, check CFM value under Setup options for all fans.



START UP (Continued)

4

Quick Setup Options Configuration

- From Main Page on Touch Screen, Press **Setup**.
- Press **LOGON**. Type Username: **setup**, Password: **change**.
- Press **Fan Setup**.
- Press **Exh Fan Setup**.
- For each Exhaust fan, verify value of **Hood Temp Rating** and **Design CFM**. If fan is rotating in the wrong direction, change **Fan Direction**.
- Press **Back** and press **Sup Fan Setup**.
- For each Supply fan, verify value of **Design CFM** and **Minimum CFM for Tempered Units**. If fan is rotating in the wrong direction, change **Fan Direction**.
- Press **Back** and press **Back Again**.
- Press **System Options**.
- Press **Set Clock**.
- If the time is incorrect, press the time in the grey area, press **Enter** and adjust the date and time. Press **Enter** when done. Then press **Save**.
- Press **Back**, press **Back** and press **Back** again until reaching the main page again.

5

Startup and Configuration

- Refer to Startup and Configuration sections of the "Installation, Operation, and Maintenance Manual" for additional detail on how to configure the system.

TROUBLESHOOTING

Problem	Potential Cause	Corrective Action
Smoke Rollout of Hood at High Speed or 100% Operation	High speed set too low	Increase exhaust and supply fan variable frequency drive high speed set points
	Improper hood installation	Check for proper hood overhang, cross drafts or improper hood design
Smoke Rollout of Hood at Low Speed Operation	Low Speed set too low	Increase exhaust and supply fan variable frequency drive low speed set points
	Improper hood installation	Check for proper hood overhang, cross drafts or improper hood design
Fans Never Go to High Speed	Dirty temperature sensor	Clean grease and dirt from sensor
	High Set Point on Temperature Control Set Too High	Decrease high temperature set point. This will force the fans to high speed at a lower exhaust temperature.
Fans Never Go to Low Speed	Low Temperature set point on temperature control set too high	Reduce low temp set point by 2 degrees. This will allow cooking equipment to further cool and prevent cycling. Repeat this step until satisfied.
Fans Spin Wrong Direction	VFD Output wiring incorrect	Change the Fan direction on the Fan Setup option screens.
Exhaust Fan On and Supply Fan will not Start	Broken supply fan belt	Replace fan belt
	Fire system not armed	Fire system distributor must arm fire system
Touch Screen Interface not powered	No power into enclosure	Check main 120V power supply
Fan icon On but No Fan Comes On	Broken fan belt	Replace fan belt
	Variable frequency drive error	Clear error on variable frequency drive. Refer to drive manual.
	Loose wiring connection	Check wiring connections on VFDs
Light icon On but No Lights Come On	Light bulbs are blown	Replace hood light bulbs
	Loose wiring connection	Check light terminal block wiring connections